

REVISION RECORD			
REV	ECO	DESCRIPTION	DRFT

NOTES:

MATERIAL :

- 1. HOUSING MATERIAL : GLASS FILLED POLYESTER UL94V-0.
- 2. CONTACT MATERIAL : PHOSPHOR BRONZE $\phi 0.46\text{mm}$.
- 3. PLATING : GOLD PLATING OVER NICKEL.

ELECTRICAL:

- 1. VOLTAGE RATING : 125 VAC RMS.
- 2. CURRENT RATING : 1.5 AMP.
- 3. CONTACT RESISTANCE : 30 MILLIOHMS MAX.
- 4. INSULATION RESISTANCE : 500 MEGOHMS MIN @ 500V DC .
- 5. DIELECTRIC WITHSTANDING RESISTANCE : 1000V AC RMS 50Hz. 1MIN.

MECHANICAL:

- 1. DURRABILITY : 750 CYCLES MIN.
- 2. PCB RETENTION PRE-SOLDER : 1 LB MIN.

ENVIRONMENTAL:

- 1. STORAGE : -40°C~+85°C
- 2. OPERATION : 0°C TO 70°C.

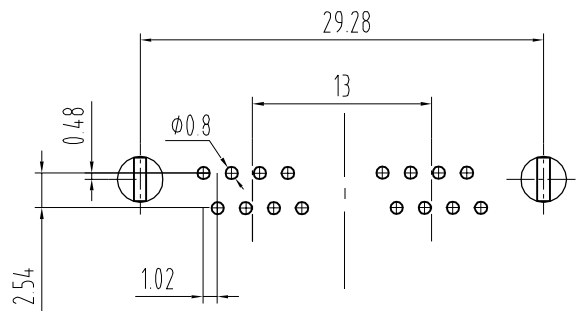
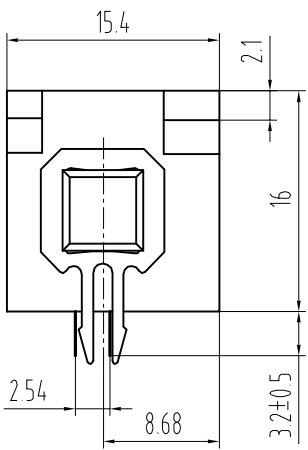
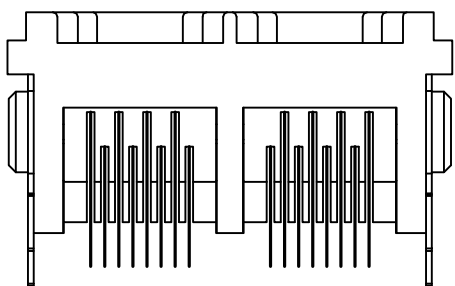
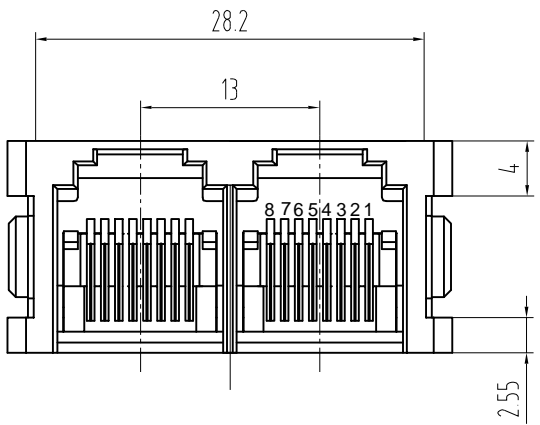

PC Board Layout
Component Side Shown

DETAILED LISTS	MM ← INCH →		DFTO SHB	DATE 2007.05.03
	TOLERANCES EXCEPT AS NOTED		CHKD LANBO	DATE 2007.05.03
	MM		MFD	DATE
	.0 ± 0.15	±	APPVL	DATE
	.00 ± 0.075	±	MATERIAL :	
.000 ± 0.05	±	QT'Y :		
ANGLES ± 0.5		FINISH :		
		SCALE :		
THIRD ANGLE PROJECTION				

Coorle 库乐科技

TITLE
5225 8P8C 1*2 180D

DRAWING NO. TESSD1001

/PART NO.

DO NOT SCALE DRAWING

SHEET X

SIZ
A8